

## Fuelling products

# Couplings

FCMY 107M5L & 108M5L - Low Pressure Coupling, FCMY 107M5H & 108M5H - High Pressure Coupling, Sealing Cap FCMY122M2

### 2.5 inch Aviation Tank Unit



The FCMY107M5 & 108M5 Series Aviation Tank Units are designed for use in aviation refuelling systems with a maximum working pressure of 10.2 bar (150 psi), in conjunction with 2 1/2" bayonet type aviation hose units.

The Mk5 version can be identified by its unplated adaptor, separate aluminium valve seating and one piece valve head. The suffix 'L' in the unit part number indicates that the unit is suitable for use where the coupling pressure does not exceed 5.5 bar (80 psi). Units with the suffix 'H' have a pressure equalising valve to facilitate coupling on systems where the coupling pressure exceeds 5.5 bar (80 psi).

The FCMY122M2 sealing cap should be used to prevent the ingress of dirt or water. It seals by means of a dual 'O'ring spring-loaded plate.

The Mk2 version can be identified by the three integral lugs which have replaced the roller assemblies.

## Meggitt Control Systems

**Our product competencies & services:**  
Aerospace valves | Thermal management solutions | Environmental control systems | Electro-mechanical products  
Ground fuelling products | Energy products | Aftermarket services

**MEGGITT**  
smart engineering for  
extreme environments

## Fuelling products

# Couplings

FCMY 107M5L & 108M5L - Low Pressure Coupling, FCMY 107M5H & 108M5H - High Pressure Coupling, Sealing Cap FCMY122M2

## Specification

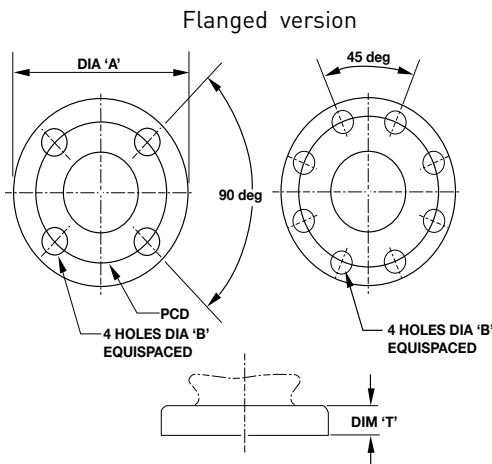

PART No.	Flange Type	Selectivity	No. of Holes	"A" Dia	"B" Dia	PCD	Dim "T"
FCMY108M5L	3" ASA150	N/S	4	7.5	0.75	6	0.875
FCMY108M5H	3" ASA150	N/S	4	7.5	0.75	6	0.875
FCMY108M5L/S1-S3	3" ASA150	S1-S3	4	7.5	0.75	6	0.875
FCMY108M5H/S1-S3	3" ASA150	S1-S3	4	7.5	0.75	6	0.875
FCMY108M5L/S4-S5	3" ASA150	S4-S5	4	7.5	0.75	6	0.875
FCMY108M5H/S4-S5	3" ASA150	S4-S5	4	7.5	0.75	6	0.875
FCMY108M5LA	2.5" ASA150	N/S	4	7	0.75	5.5	0.875
FCMY108M5HA	2.5" SA150	N/S	4	7	0.75	5.5	0.875
FCMY108M5LA/S1-S3	2.5" ASA150	S1-S3	4	7	0.75	5.5	0.875
FCMY108M5HA/S1-S3	2.5" ASA150	S1-S3	4	7	0.75	5.5	0.875
FCMY108M5LA/S4-S5	2.5" ASA150	S4-S5	4	7	0.75	5.5	0.875
FCMY108M5HA/S4-S5	2.5" ASA150	S4-S5	4	7	0.75	5.5	0.875
FCMY108M5LB	3" TTMA	N/S	8	5.625	0.437	4.875	0.5
FCMY108M5HB	3" TTMA	N/S	8	5.625	0.437	4.875	0.5
FCMY108M5LB/S1-S3	3" TTMA	S1-S3	8	5.625	0.437	4.875	0.5
FCMY108M5HB/S1-S3	3" TTMA	S1-S3	8	5.625	0.437	4.875	0.5
FCMY108M5LB/S4-S5	3" TTMA	S4-S5	8	5.625	0.437	4.875	0.5
FCMY108M5HB/S4-S5	3" TTMA	S4-S5	8	5.625	0.437	4.875	0.5
FCMY108M5LC	65MM(2.5)DIN	N/S	8	154MM	11MM	130MM	0.5
FCMY108M5HC	65MM(2.5)DIN	N/S	8	154MM	11MM	130MM	0.5
FCMY108M5LC/S1-S3	65MM(2.5)DIN	S1-S3	8	154MM	11MM	130MM	0.5
FCMY108M5HC/S1-S3	65MM(2.5)DIN	S1-S3	8	154MM	11MM	130MM	0.5
FCMY108M5LC/S4-S5	65MM(2.5)DIN	S4-S5	8	154MM	11MM	130MM	0.5
FCMY108M5HC/S4-S5	65MM(2.5)DIN	S4-S5	8	154MM	11MM	130MM	0.5

PART No.	Thread Type	Selectivity
FCMY108M5L	2.5" BSP	N/S
FCMY108M5H	2.5" BSP	N/S
FCMY108M5L/S1-S3	2.5" BSP	S1-S3
FCMY108M5H/S1-S3	2.5" BSP	S1-S3
FCMY108M5L/S4-S5	2.5" BSP	S4-S5
FCMY108M5H/S4-S5	2.5" BSP	S4-S5
FCMY108M5LN	2.5" NPT	N/S
FCMY108M5HN	2.5" NPT	N/S
FCMY108M5LN/S1-S3	2.5" NPT	S1-S3
FCMY108M5HN/S1-S3	2.5" NPT	S1-S3
FCMY108M5LN/S4-S5	2.5" NPT	S4-S5
FCMY108M5HN/S4-S5	2.5" NPT	S4-S5

Threaded version

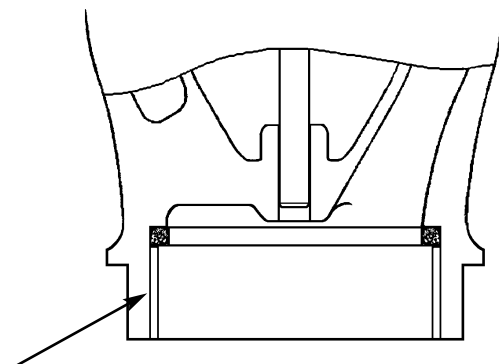

BSP or NPT Thread

## Meggitt Control Systems

Our product competencies & services:  
Aerospace valves | Thermal management solutions | Environmental control systems | Electro-mechanical products  
Ground fuelling products | Energy products | Aftermarket services

**MEGGITT**  
smart engineering for  
extreme environments

## Fuelling products

# Couplings

FCMY 107M5L & 108M5L - Low Pressure Coupling, FCMY 107M5H & 108M5H - High Pressure Coupling, Sealing Cap FCY122M2

## Specification

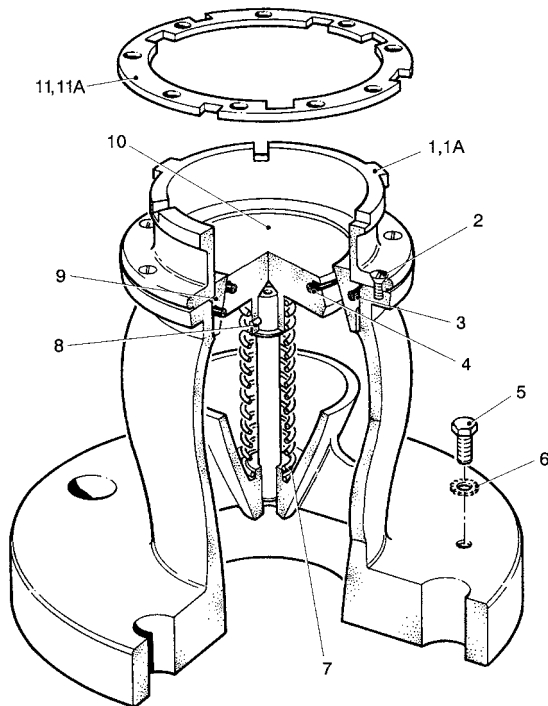

All internal components are common for both FCY107M2 and FCY108M2 versions

### Aviation Tank Unit FCY 107M5L - Low Pressure Coupling

ITEM	PART No.	DESCRIPTION	Qty
1	FCCZ 1454	TANK UNIT ADAPTOR-NON SELECTIVE	1
1A	FCCZ 1455	TANK UNIT ADAPTOR-SELECTIVE	1
2	ZS4001A0208A	SCREW, 2BA x 11/2" LONG CSK. HD., ST. STL	19
3	Z032M079530A	"O" RING	1
4	ZAXX0099-1	"O" RING	1
5	ZS2228A0206A	SCREW 2BA	1
6	ZW8206A02A	WASHER 2BA INTERNAL SHAKE PROOF	1
7	ZASZ0001-21	SPRING	1
8	ZT4001E0414A	TENSION PIN 1/8" DIAMETER	1
9	FCSZ 1453	VALVE HEAD SEATING	1
10	FCMS 1460	VALVE HEAD ASSY, LOW PRESSURE	1
11	FCSZ 1412	SETTING RING, POSITIONS 1 TO 3	1
11A	FCSZ 1413	SETTING RING, POSITIONS 4 & 5	1

### Aviation Tank Unit FCY 107M5H - High Pressure Coupling

ITEM	PART No.	DESCRIPTION	Qty
10	FCSZ 1402	SPRING	1
10A	FCMZ 1396	PIP VALVE SUB-ASSEMBLY	1
10B	FCMS 1459	VALVE HEAD ASSY, HIGH PRESSURE	1

ITEMS 1 - 9, 11 AND 11A AS LOW PRESSURE COUPLING (SEE TABLE ABOVE)

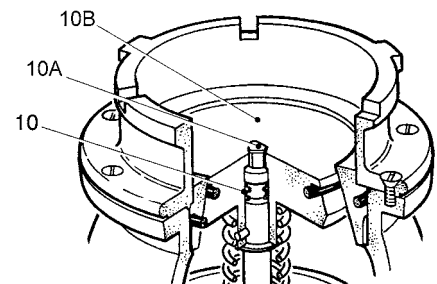

## Meggitt Control Systems

Our product competencies & services:  
Aerospace valves | Thermal management solutions | Environmental control systems | Electro-mechanical products  
Ground fuelling products | Energy products | Aftermarket services

**MEGGITT**  
smart engineering for  
extreme environments

## Fuelling products

# Couplings

FCMY 107M5L & 108M5L - Low Pressure Coupling, FCMY 107M5H & 108M5H - High Pressure Coupling, Sealing Cap FCMY122M2

## Specification

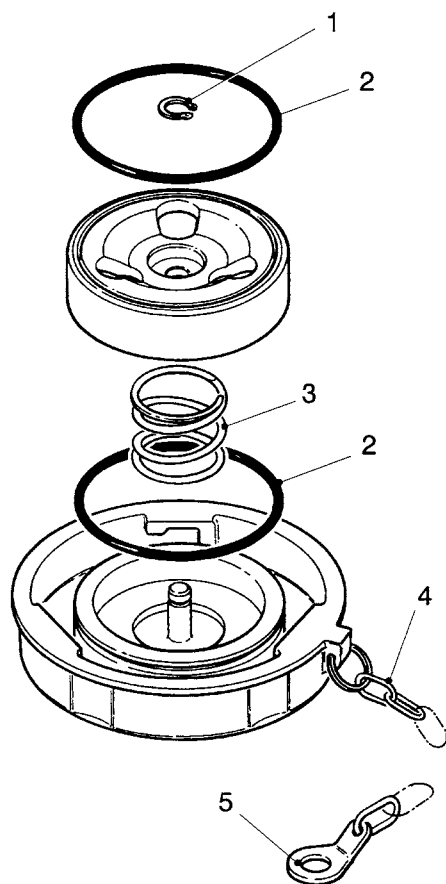

### Selectivity

Selective units are fitted with setting rings. These have slots cut into them to match up with the corresponding pins on the selective sleeve on the hose unit. Care must be taken when reassembling such units to ensure that the ring is returned to its original position.

### Maintenance

Inspect the unit at weekly intervals for the following:

- Evidence of leakage
- Cleanliness and corrosion
- Bayonet Lugs,
  1. Wear to be checked using Wear Gauge, Pt No. TASS5050, (Min. thickness, 5.97 mm (0.235in)
  2. Distortion or bending not to exceed 0.4mm (0.015in).
- Condition of setting ring slots (if used)
- Serviceability of cap
- Security of fastenings

MAXIMUM TEST PRESSURE, 15.3 bar (225 psi)  
SAFE WORKING PRESSURE, 10.2 bar (150 psi).

### Spare Parts

When ordering spare parts, please quote the following:

- UNIT PART NUMBER
- ITEM PART NUMBER
- FULL DESCRIPTION
- PUBLICATION NUMBER

### Sealing Cap FCMY 122M2

ITEM	PART No.	DESCRIPTION	Qty
12	ZASZ0058-35	EXTERNAL CIRCLIP	1
34	ZARZ0041-62	"O" RING	2
5	FCSZ206	SPRING	1
	ZAMZ 0079-1	CHAIN/KEY RINGS	1
	HUSZ4340	CAP PLATE	1

NOTE: ONLY THOSE ITEMS LISTED ARE AVAILABLE AS SPARES

## Contact

HP Aviation Group

Address: 1/9 Newry Drive,  
New Gisborne, 3438,  
Australia

Telephone: +61 35428 4846  
+61 400 234 997

Email:  
sales@hpaviationhoses.com.au

Website:  
www.hpaviationhoses.com.au

## Meggitt Control Systems

Our product competencies & services:  
Aerospace valves | Thermal management solutions | Environmental control systems | Electro-mechanical products  
Ground fuelling products | Energy products | Aftermarket services

**MEGGITT**  
smart engineering for  
extreme environments